



# SERIES 2500 PANEL SYSTEM



## STRUCTURAL SYSTEM FOR COMMERCIAL AND INSTITUTIONAL

### 2" STRUCTURAL AND ARCHITECTURAL MECHANICALLY SEAMED PANEL SYSTEM

Designed particularly as a structural roof system for pre-engineered buildings, Englert's Series 2500 Armco style single-lock panel is the industry's most extensively tested system, with over 50 years of history in the field. The 2500 profile incorporates a unique heavy duty interlock clip that secures the system while allowing thermal expansion and contraction.

### SYSTEM APPLICATIONS

- Heavy duty for commercial and industrial use
- 1/2"/12" minimum slope
- Can be installed over a solid deck or open framing
- Requires seam sealant if air and water tests are specified
- Engineering available for various panel sizes and substrates upon request

### SUBSTRATES

- 26, 24 and 22 gauge steel
- .032" and .040" aluminum
- 16 oz. and 20 oz. copper
- .7 and .8 mm zinc (RheinZink)



**SERIES 2500 PANEL SYSTEM**



# SERIES 2500 PANEL SYSTEM

## FINISHES

Englert's Series 2500 system is available in a wide variety of coatings and colors. See the Englert color card for our full range of standard colors and paint system specifications.

Englert can match the color of virtually any material – including brick, wood and fabric – with short lead times as needed. Custom colors are available in quantities as low as 5,000 lbs. on steel or aluminum.

## SYSTEM WARRANTIES

- Galvalume Plus® – 25-year steel warranty on acrylic coated Galvalume®
- PermaColor 2000 – 30-year steel or aluminum warranty on Kynar 500®/Hylar 5000® coating
- PermaMetallic 2000 – 20-year steel or aluminum warranty on Kynar 500®/Hylar 5000® coating
- Siliconized Modified Polyester – 15-year steel or aluminum coating warranty

## RATINGS AND CERTIFICATIONS

- UL-90 rated over 22 gauge metal deck at 16" wide with clips at 30" o.c. (24 ga. steel)
- UL-90 rated over 16 gauge purlins at 16" wide with clips at 60" o.c. (24 ga. steel)
- ASTM-E-1646-95 and ASTM-E-331 water penetration tested
- ASTM-E-1680-95 and ASTM-E-283 air infiltration tested
- ASTM-E-1592-98 uplift tested (24 and 22 ga. steel, .040" aluminum)
- ASTM-E-84 Class A fire rating on coating and substrate (24 ga. steel)
- FM-I90 rated over 16 gauge purlins at 16" wide with clips at 60" o.c. (24 ga. steel)

Distributed by:



### Series 2500 2" Mechanically Seamed

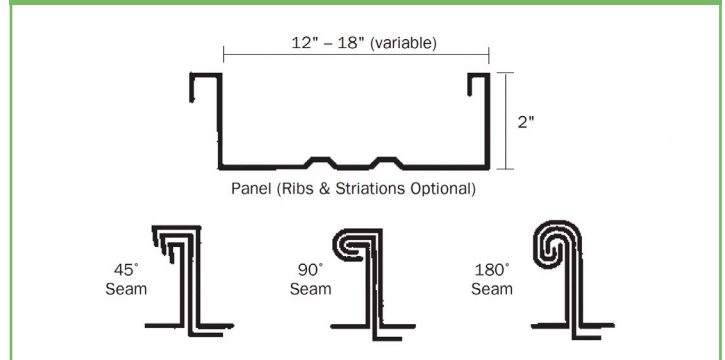

### Allowable Uniform Live Load

No. of Spans	4'-0"	4'-6"	5'-0"	5'-6"	6'-0"
<b>14" Width — 24 ga. steel</b>					
2	79	62	50	41	34
3 or more	92	72	58	48	40
<b>14" Width — 22 ga. steel</b>					
2	110	87	70	58	48
3 or more	129	102	82	68	57
<b>16" Width — 24 ga. steel</b>					
2	69	54	44	36	30
3 or more	80	63	51	42	35
<b>16" Width — 22 ga. steel</b>					
2	97	76	61	51	42
3 or more	113	89	72	59	50
<b>18" Width — 24 ga. steel</b>					
2	61	48	39	32	27
3 or more	71	56	45	37	31
<b>18" Width — 22 ga. steel</b>					
2	86	68	55	45	37
3 or more	100	79	64	53	44

*Note: Load values shown may be increased by 1/3 for allowable wind load.*